

Rotation Capacity of Pre-Qualified Steel Moment Connections:

A Yield-Line Approach

Kyungkoo Lee, Seoul National University
Bozidar Stojadinovic, UC Berkeley

Motivation and Objectives

- ◆ Modern fully-restrained moment connections must be pre-qualified by testing
- ◆ Develop a method to evaluate new connection designs ahead of a test:
 - Phenomenological
 - Able to model strength degradation due to local buckling
 - Able to model failure due to low-cycle fatigue

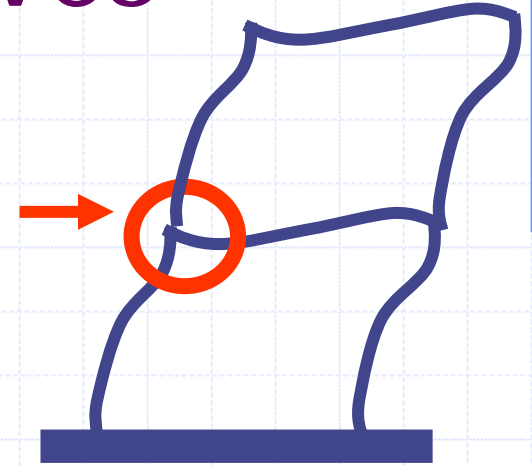

Rotation Capacity: Conventional Behavior Ranges

◆ Elastic

◆ Plastic

◆ Good for structural mechanics theory

◆ Bad for a simple model!

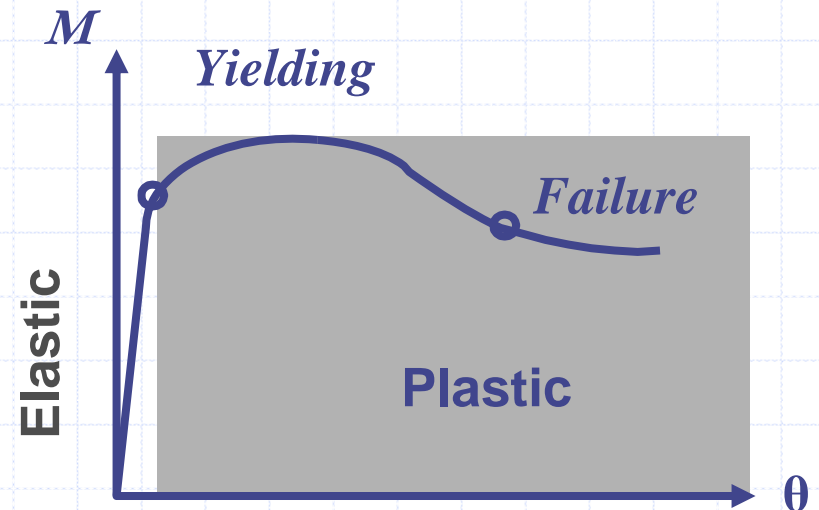
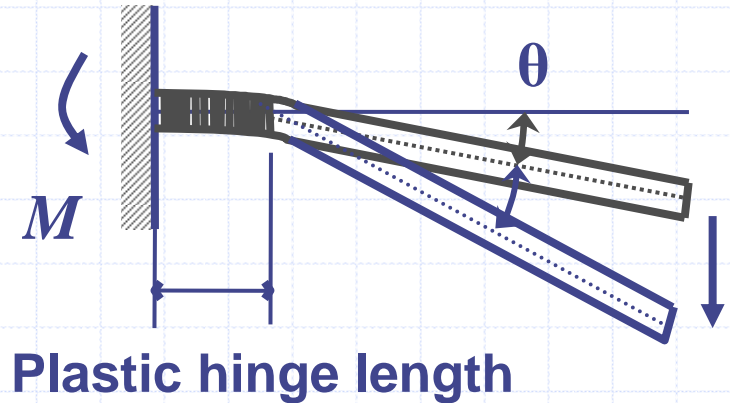

Rotation Capacity: Practical Behavior Ranges

- ◆ Pre-buckling:
 - Plane-section fiber-discretized model
- ◆ Post-buckling
 - Yield-line plastic hinge model

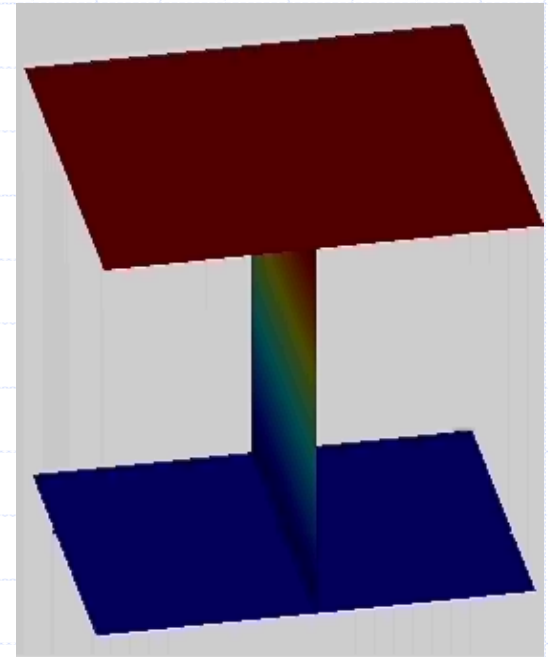
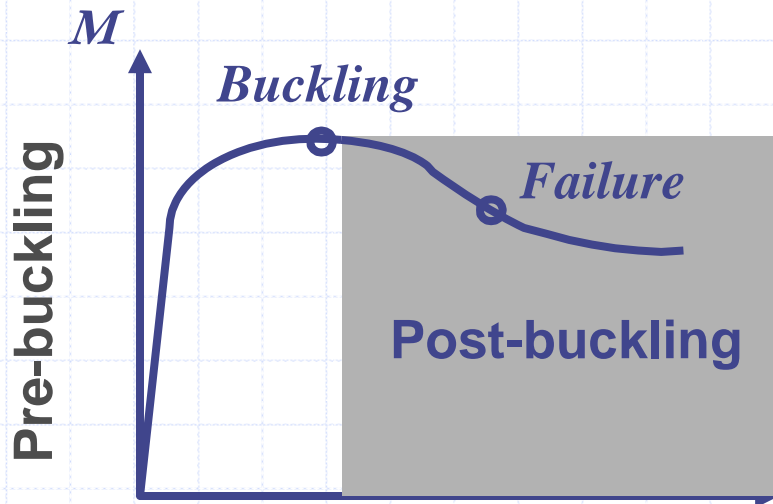

Yield-Line Plastic Hinge Model

- ◆ Plane sections do not remain plane
- ◆ Model the buckled plastic hinge:
 - Assume a folding pattern and a plastic hinge length
 - Place yield lines along the folds
- ◆ Pioneered by Gioncu and Petcu (1997)



Uni-Directional Yield-Line Plastic Hinge Model

- ◆ Geometry: folded shape
- ◆ Kinematics:
 - Yield line rotation and plastic zone deformation
 - Plastic hinge rotation
 - Compatibility
- ◆ Equilibrium:
 - Cross-section stress resultants
 - Plastic work, external and internal

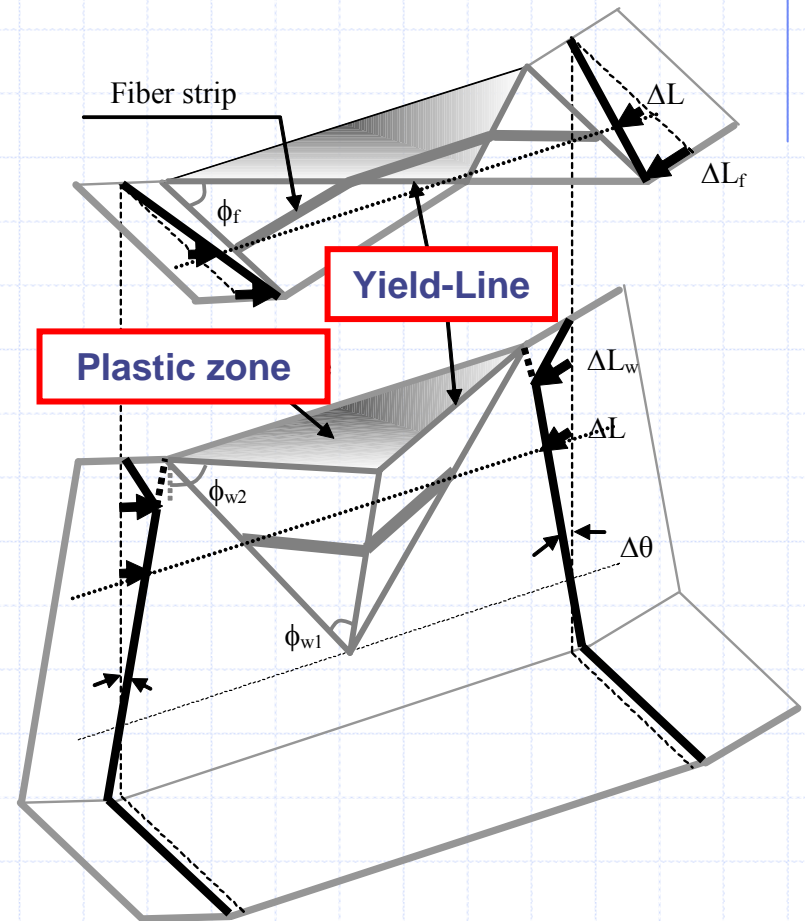

Bi-Directional (Cyclic) Yield-Line Plastic Hinge Model

◆ Geometry:
superimposed uni-
direction folded shapes

◆ Kinematics:
■ Same!
■ Step-by-step approach

◆ Equilibrium:
■ Same!
■ Plastic stresses
■ Superposition

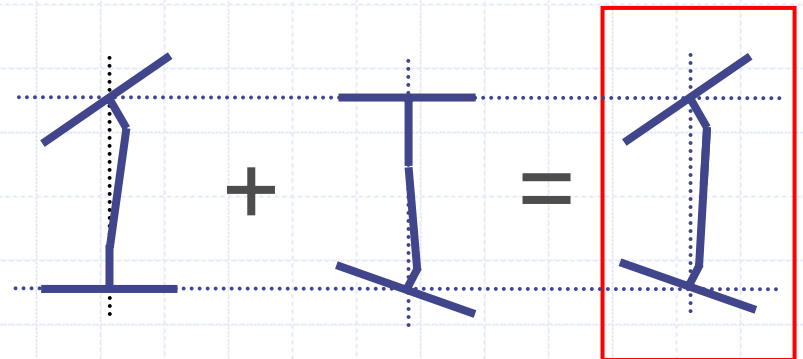
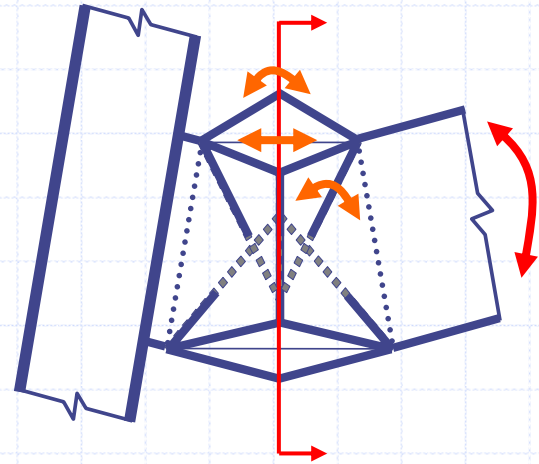

Connection Modeling and Analysis

- ◆ Column:
 - Rotation spring
- ◆ Buckled plastic hinge:
 - YLPH
- ◆ Elastic beam
 - Fiber cross section (FCS)

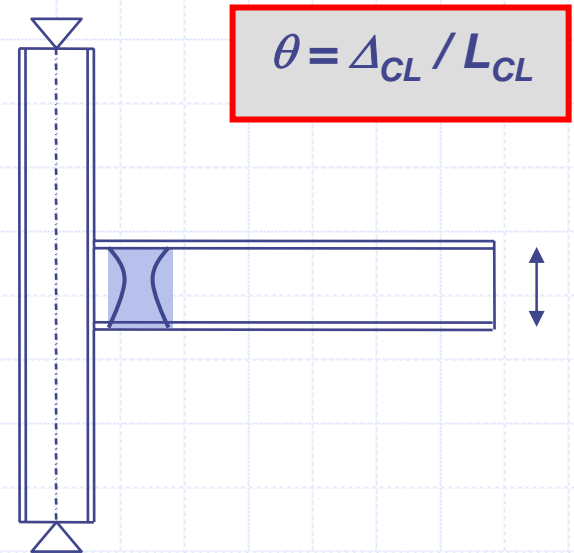
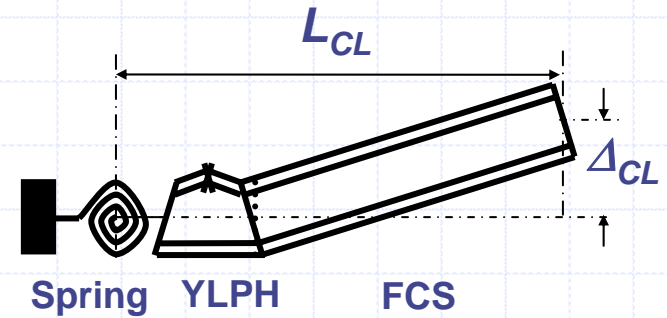

$$\delta F \cdot \Delta_{CL} = \underbrace{\delta M_{col} \cdot \theta_{col}}_{\text{Spring}} + \underbrace{\int_{\text{buckled}} \delta M \cdot \kappa dl}_{\text{YLPH}} + \underbrace{\int_{\text{plane}} \delta M \cdot \kappa dl}_{\text{FCS}}$$

Model Validation: Monotonic Loading

◆ Local flange buckling
amplitude:

- First cycle
- Second cycle

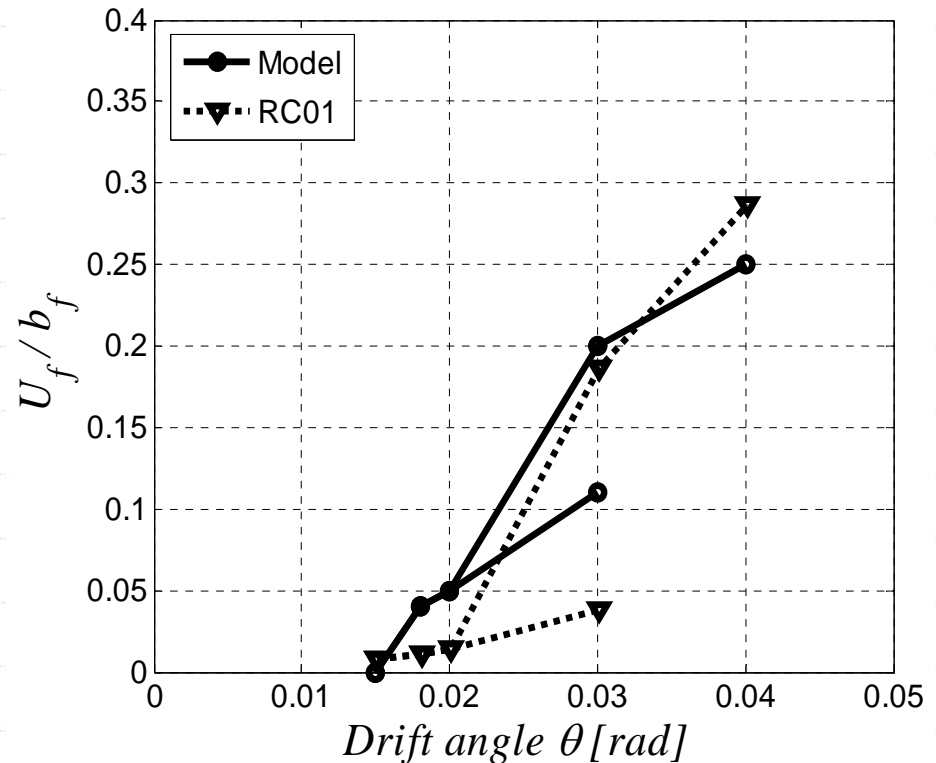

Model Validation: Monotonic Loading

- ◆ Rotation capacity under monotonic loading

$$R_a = \frac{\theta_p}{\theta_e}$$

$$\lambda_e^{Kemp} = \left[\frac{h_o}{t_w} \cdot \frac{\gamma_w}{70} \right] \left[\frac{b_f}{2t_f} \cdot \frac{\gamma_f}{9} \right] \left[\frac{L_i}{r_{yc}} \cdot \gamma_f \right]$$

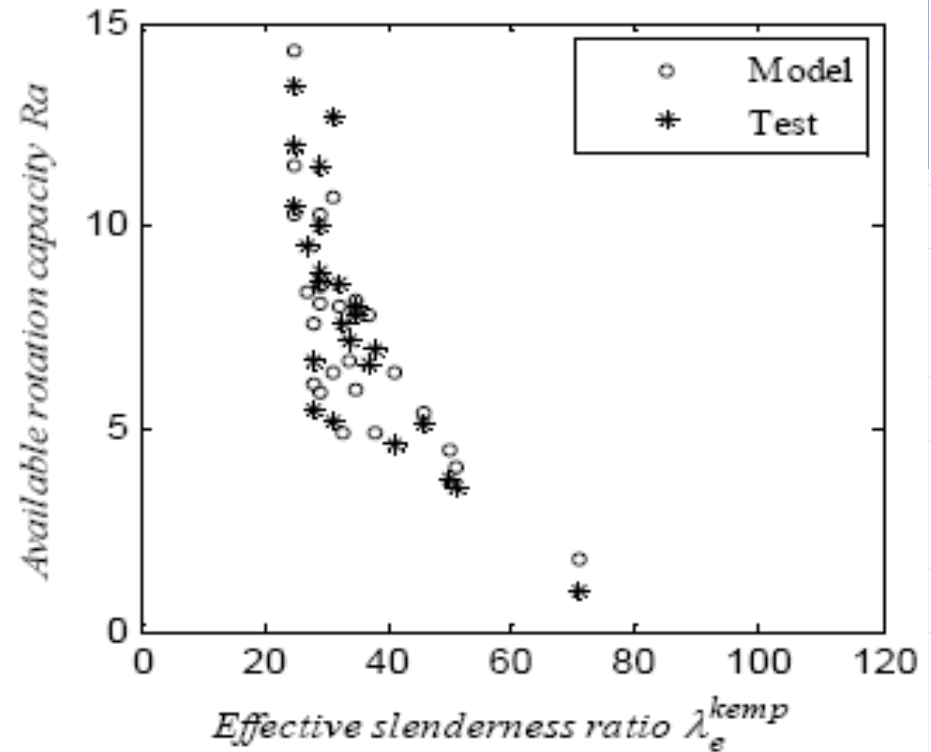

Model Validation: Degradation under Cyclic Loading

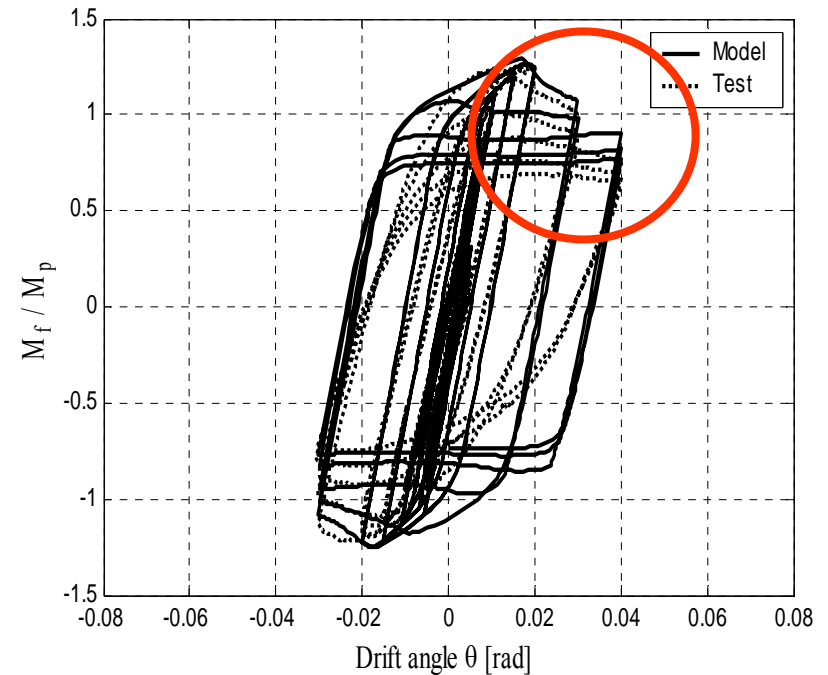
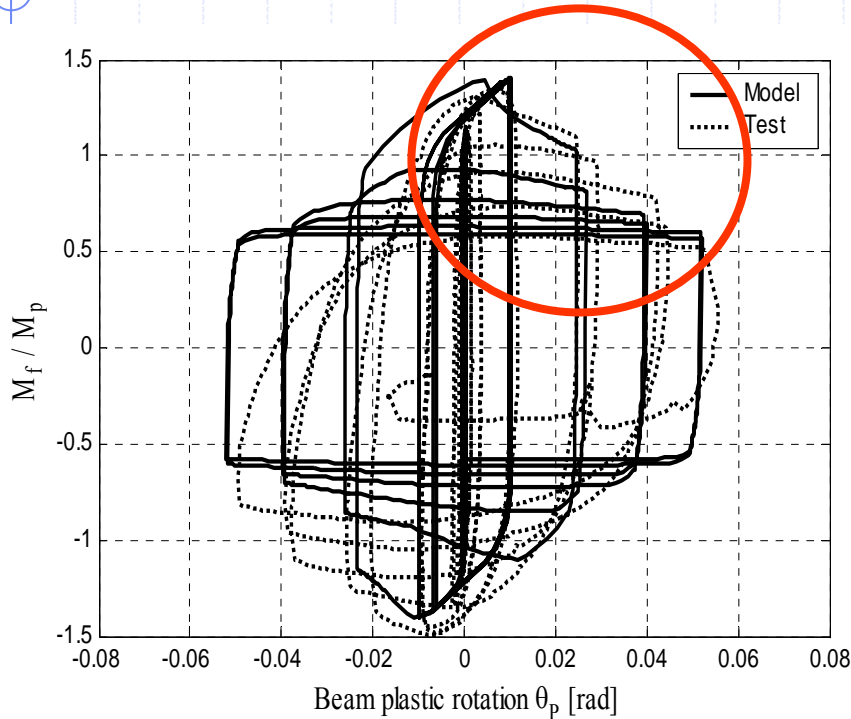

- ◆ WUF-W connection:
 - Lehigh University

- ◆ Free Flange connection:
 - University of Michigan

Low-Cycle Fatigue Failure: Definition

◆ Strain accumulation at a yield line

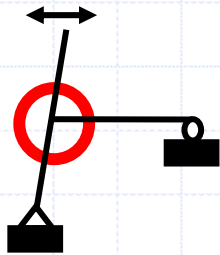
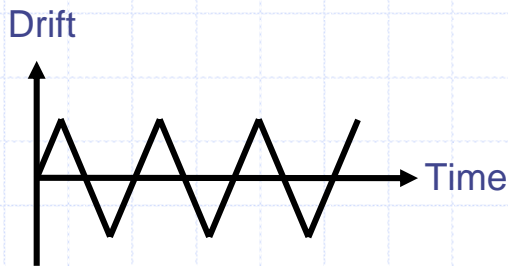

Half subassembly

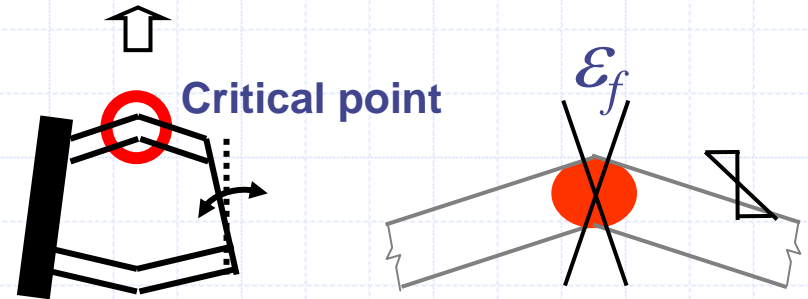
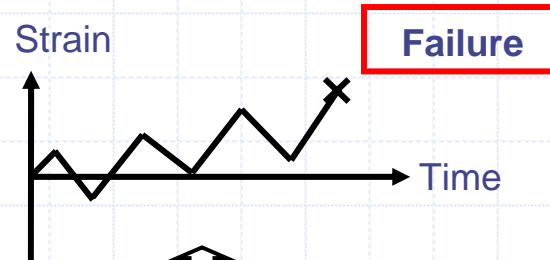

Yield-line plastic hinge

Connection Failure: Definition

Onset of local flange buckling in the beam

80% of peak strength

Nominal strength

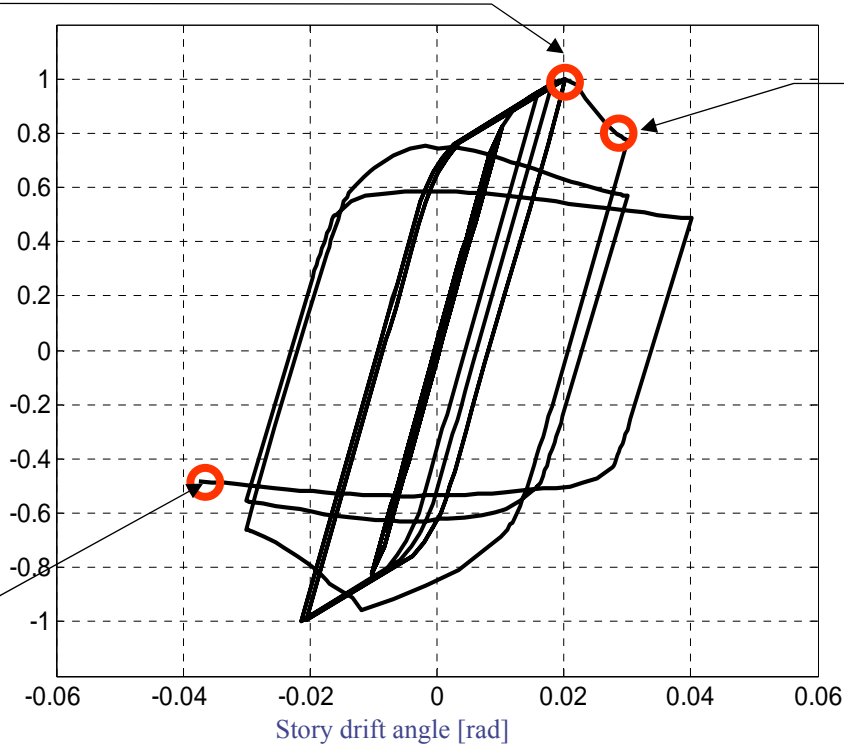

Crack initiates when $\varepsilon_f = 0.2$

Manson-Coffin Relation

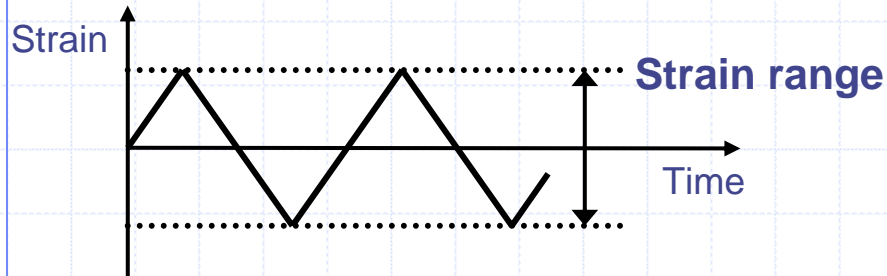

◆ Constant-amplitude loading

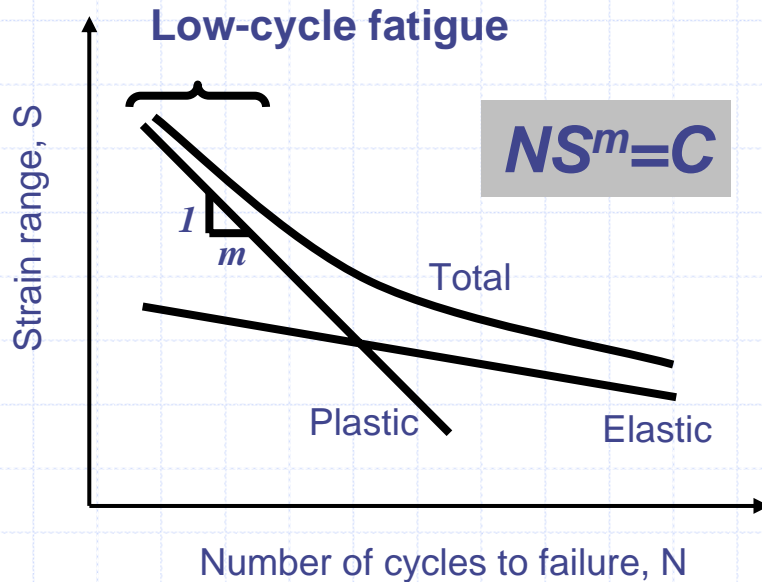

◆ Variable-amplitude loading

- Rain-flow cycle counting
- Miner's rule

Logarithmic scale

Strain-Controlled Fatigue

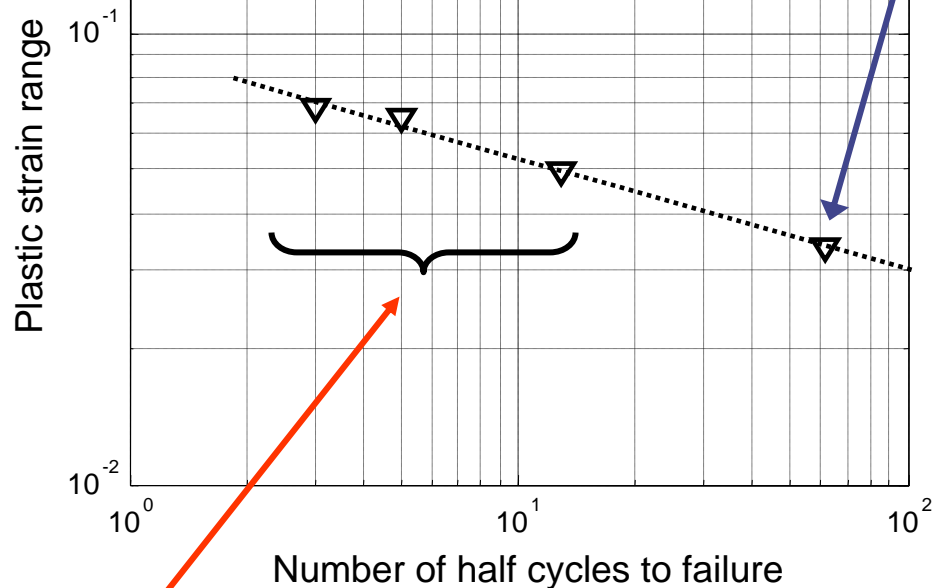
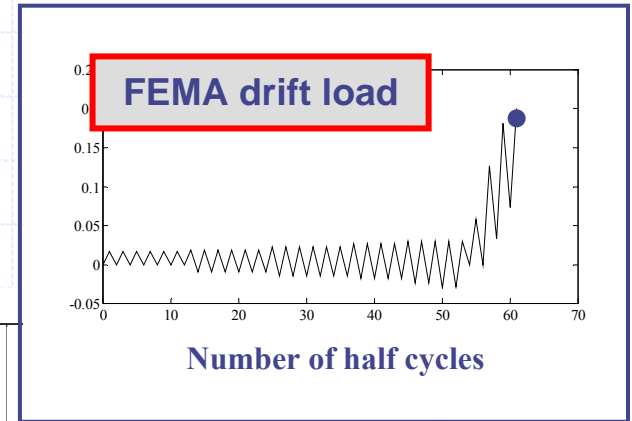
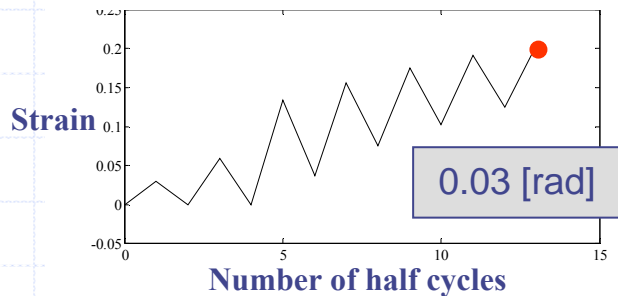
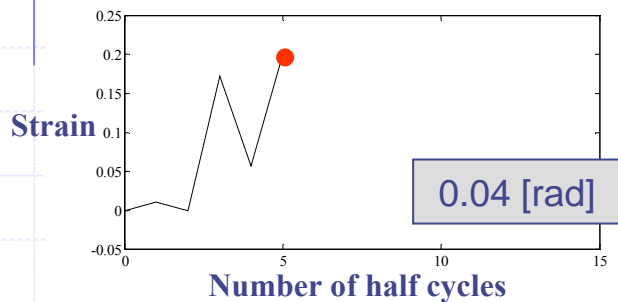
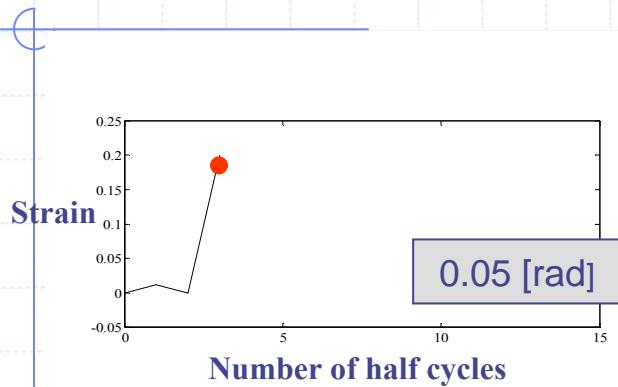

Constant-amplitude drift loadings

Moment Connection Fatigue Life Prediction using YLPH

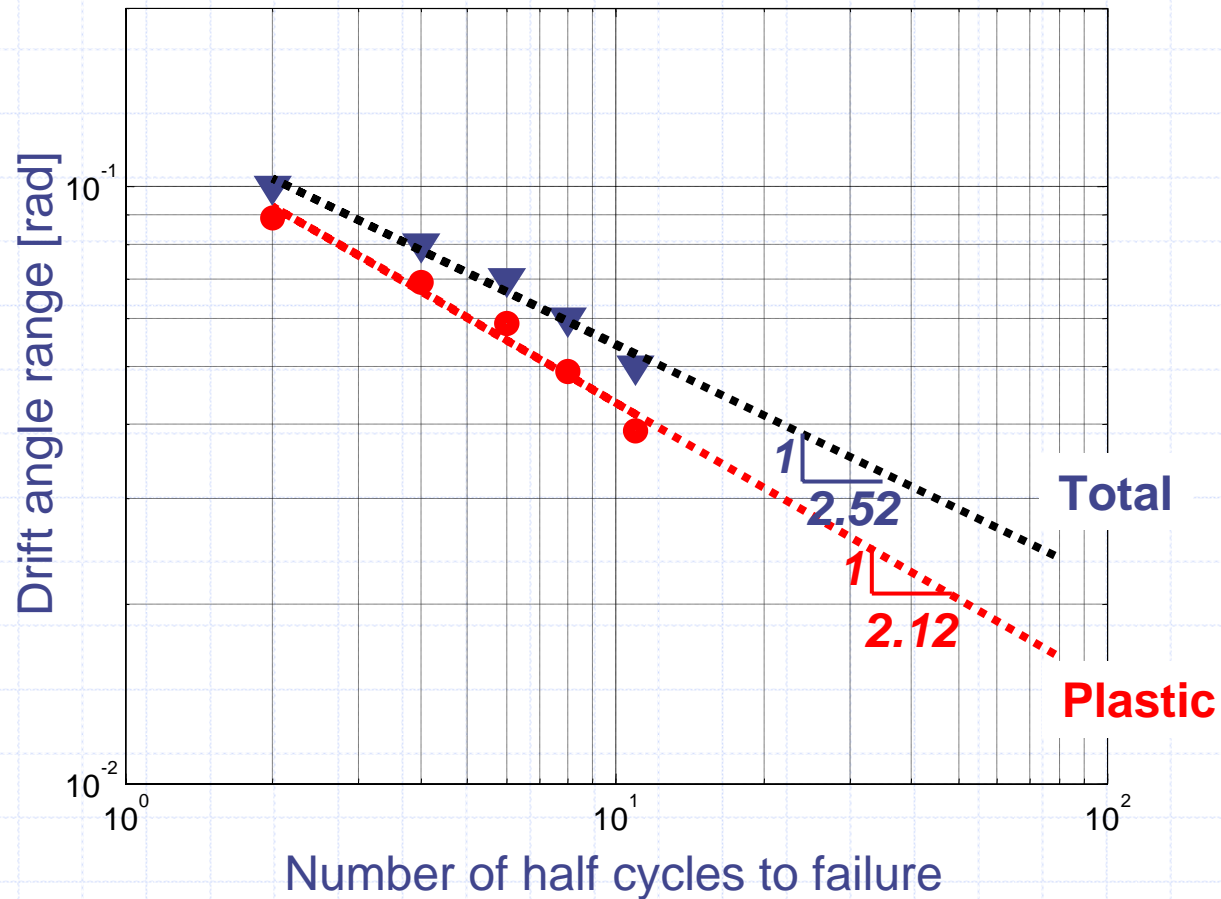

Effect of Beam Geometry: Flange Slenderness

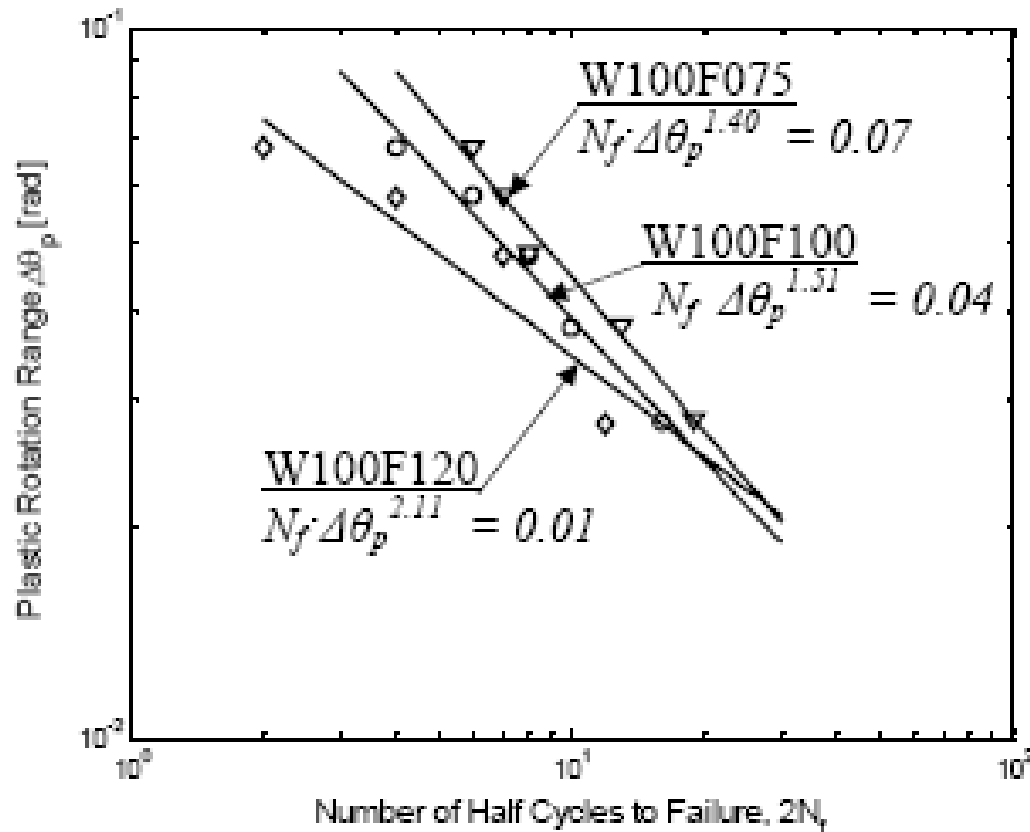

Sections with more slender flanges fail earlier

Effect of Beam Geometry: Web Slenderness

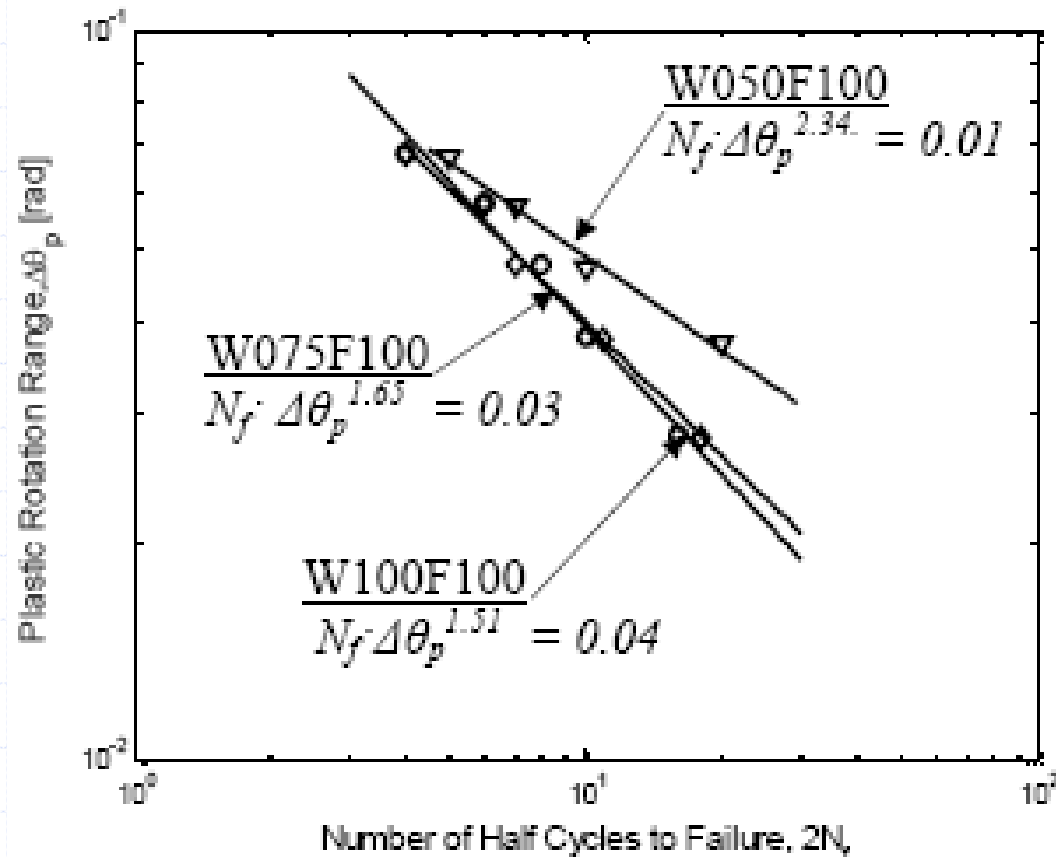

Sections with more slender webs fail earlier

Effect of Connection Type: WUF-W, RBS and Free Flange

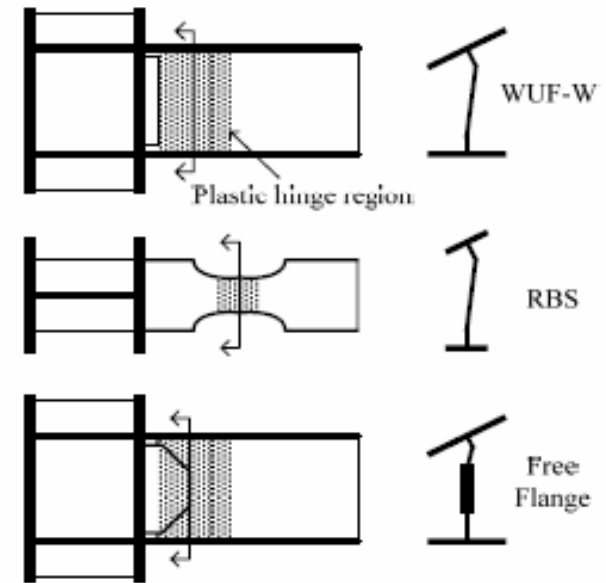
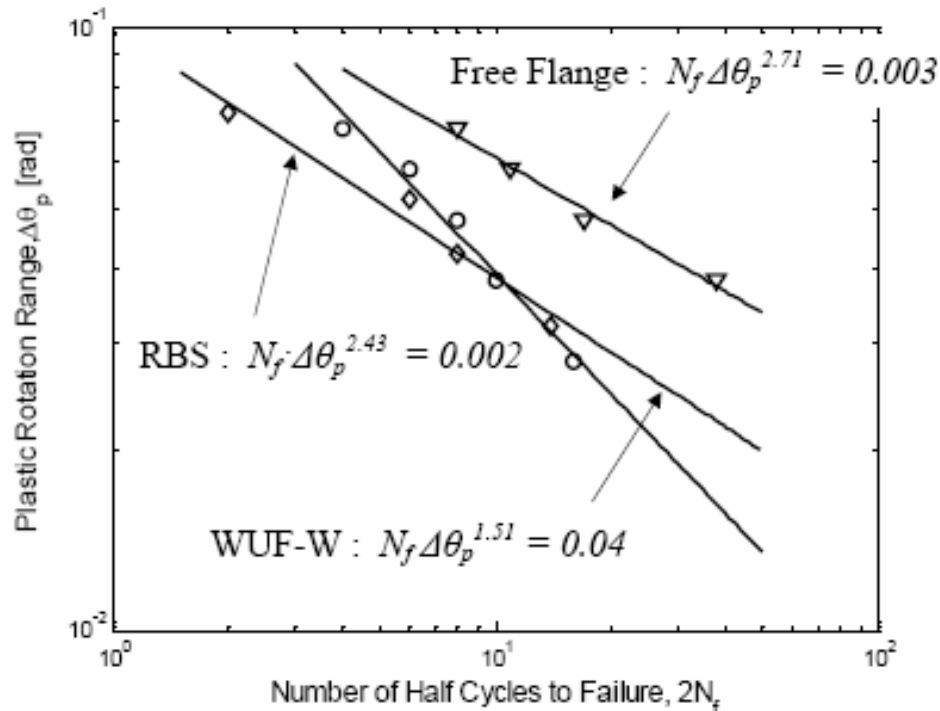

Free Flange connection resist fatigue best!

YLPH Model: Goals and Results

◆ We wanted to:

- Develop, implement and validate a simple, phenomenological connection model to capture strength degradation and low-cycle fatigue failure of steel moment connections
- Enable practitioners to evaluate the a new connection designs before a test

◆ We did this, but the model is not simple

YLPH:

Results and Future Work

- ◆ YLPH model is a not a mechanically completely consistent solution, but is a sufficiently accurate approximate solution:
 - Good agreement with test data
 - Good tool for connection failure exploration
- ◆ Needs to be implemented as:
 - A user-friendly stand-alone application
 - An OpenSees object (element)



Thank you!

University of California, Berkeley funds
used to support work on this project are
gratefully acknowledged

